

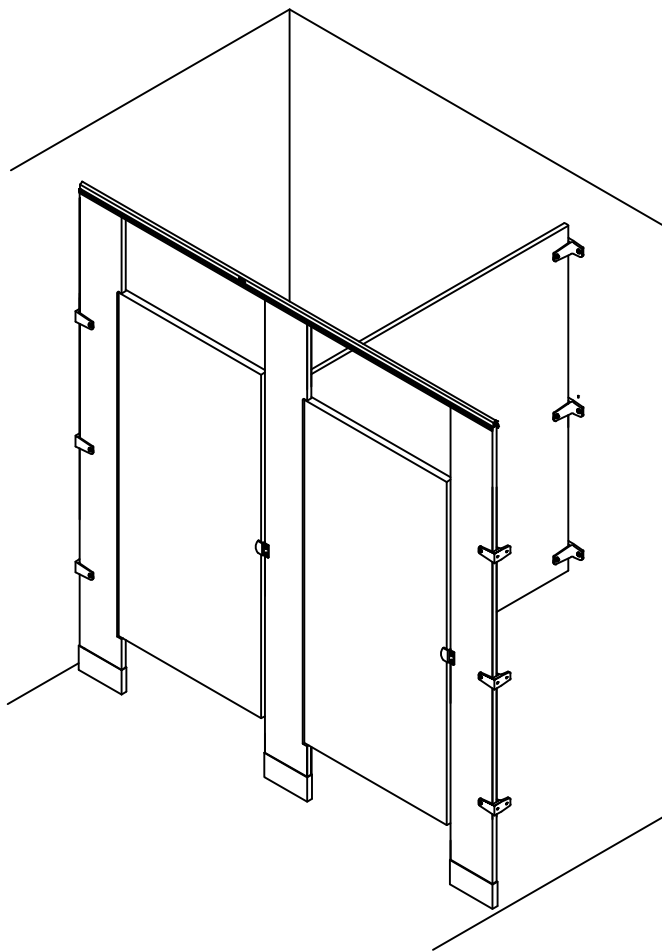

---

**INSTALLATION INSTRUCTIONS FOR**  
**POLYMER SOLID PLASTIC PARTITIONS**



**\*\*Always keep the Solid Plastic pieces stored flat to prevent warping\*\***

2171 Liberty Hill rd. Eastonollee, GA 30538 Phone:(706)827-2700 Fax:(706)827-2710  
Website: [www.globalpartitions.com](http://www.globalpartitions.com) Email: [sales@globalpartitions.com](mailto:sales@globalpartitions.com)

**STEP 1**  
**LAYOUT**  
**FLOOR ANCHORED/OVERHEAD BRACED**

NOTE:FLOOR MUST BE CONCRETE

- Review the layout drawings and package lists that have accompanied this job.
- Before proceeding,confirm that backing of walls and floor is adequate to support secure mounting of the toilet compartment units.
- Establish and mark pilaster center line from back wall.
- Establish and mark panel center lines for wall brackets.
- Establish pilaster floor fastener locations from side wall according to shop drawings. (Note floor fasteners are located 1" from edge of pilaster.)
- Mark wall bracket holes using brackets as templates.

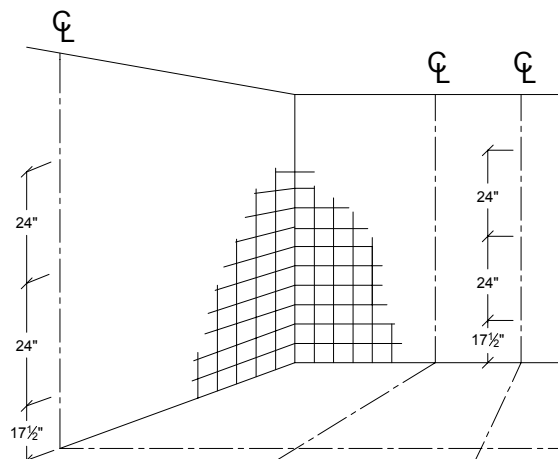
**FIGURE 1**

**STEP 2**  
**WALL BRACKETS AND FLOOR ANCHORS**

- Drill holes for wall brackets and floor anchors of appropriate size for particular fastening devices supplied. Typically, 5/16" bit for walls, 1/4" bit for compartment thru-bolts, and 3/16" bit for floors. (Note: As site conditions and hardware combinations vary, an assortment of bit sizes are recommended.)
- Insert anchoring devices in walls and secure wall brackets.
- Attach the shoes to the concrete floor using the 1/4" concrete screws. (Note: The hole in the side of the shoe should be placed on the inside of the compartment.)
- Adjust the location of the shoes according to the door opening size and secure shoes to the floor.

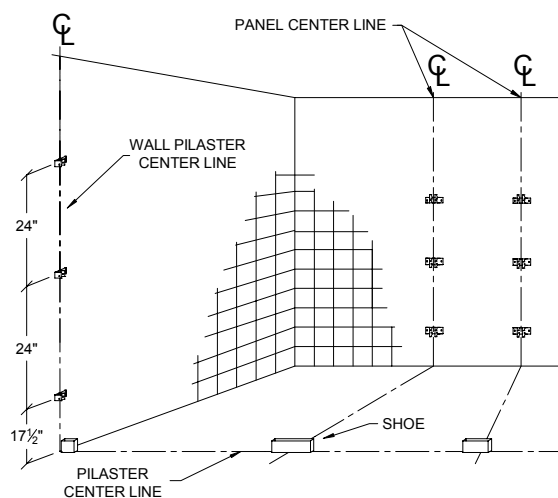
**FIGURE 2**

**STEP 3**  
**POSITION PANEL**

- Place panel on a support, 14" above the floor.
- Set it into wall brackets, but do not fasten panel at this time.

NOTE: Metal heat-sink strip will be on bottom of panel

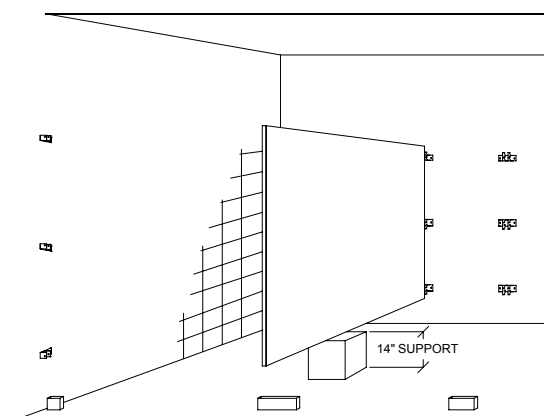
**FIGURE 3**

### **STEP 4** **PILASTER PREPARATION**

- A. Align brackets in position on rear of pilasters. Refer to layout drawings.
- B. Fasten brackets to pilaster with sheet metal screws.
- C. Pilasters at wall will not have U-brackets, but should be prepared for wall (and floor fastening) as required by compartment layout.

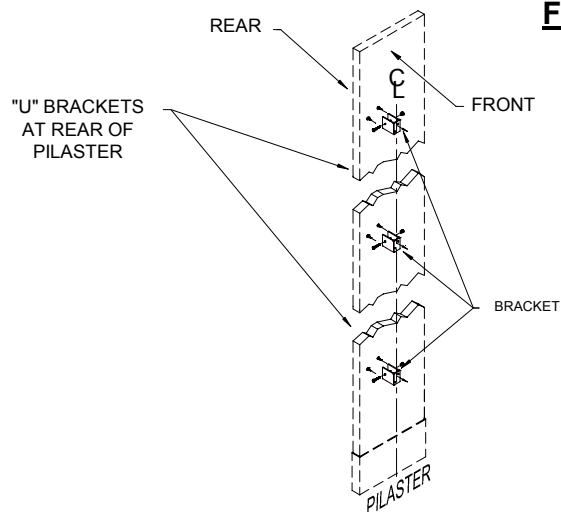
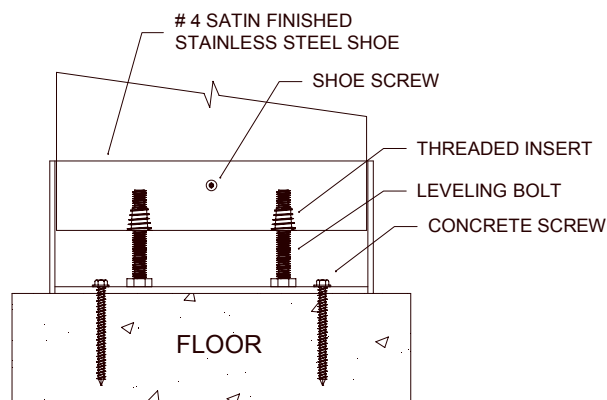

**FIGURE 4**

### **STEP 5** **INSTALL PILASTERS**

- A. Insert the leveling bolt into the threaded insert at the bottom of the pilaster.
- B. Insert the pilaster into the shoe.
- C. Level the top of all pilasters by adjusting the leveling bolt to desired position.

Note: To determine how far to insert the leveling bolt, find the highest point on the floor, and fully insert the bolt on the pilaster that will be mounted in that location. Adjust all other leveling bolts accordingly.



FLOOR MOUNTING DETAIL

**FIGURE 5**

### **STEP 6** **SECURING PILASTER/PANEL**

- A. Level the panel and adjust the gaps at either end.
- B. Secure the panel to the wall and pilaster using through bolts.
- C. Remove panel support device.
- D. Plumb each pilaster and secure with headrail. (See pg 13 for headrail detail.)
- E. Secure the pilaster to the shoe using shoe screws.

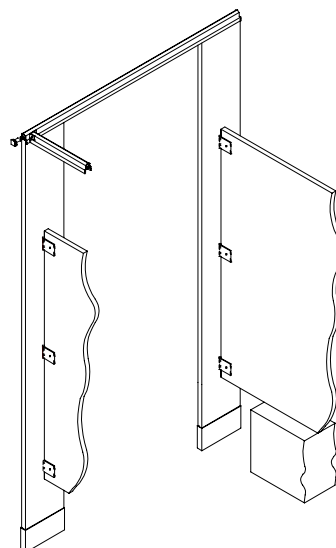

**FIGURE 6**

**FLOOR ANCHORED/OVERHEAD BRACED  
PANEL TO PILASTER/WALL  
TWO EAR ASSEMBLY  
POLYMER**

Pilasters must be both plumb and level. To assist in leveling, headrail may be lightly positioned across adjacent pilasters (do not fasten at this time)

- A. Plumb panel and fasten panel to two ear bracket at wall with through bolts.
- B. Plumb pilaster and fasten pilaster to panel using through bolts..







Panel Hardware Kit (P/N 8445020) Includes: ALUMINUM			
PART ID.		DESCRIPTION	QTY
1		Two Ear Alum. Bracket	(3)
2		Alum. "U" Bracket	(3)
3		Vandal Resistant 1" Step Bolts	(6)
4		Vandal Resistant 5/8" Barrel Nut	(6)
5		Vandal Resistant 2 1/2" S.M.S	(6)
6		Plastic Shields	(6)
7		Vandal Resistant 5/8" S.M.S	(6)



FIGURE A  
Panel to wall

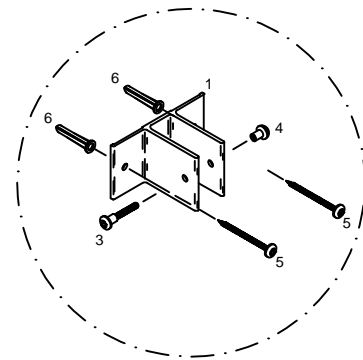

FIGURE A  
Panel to wall

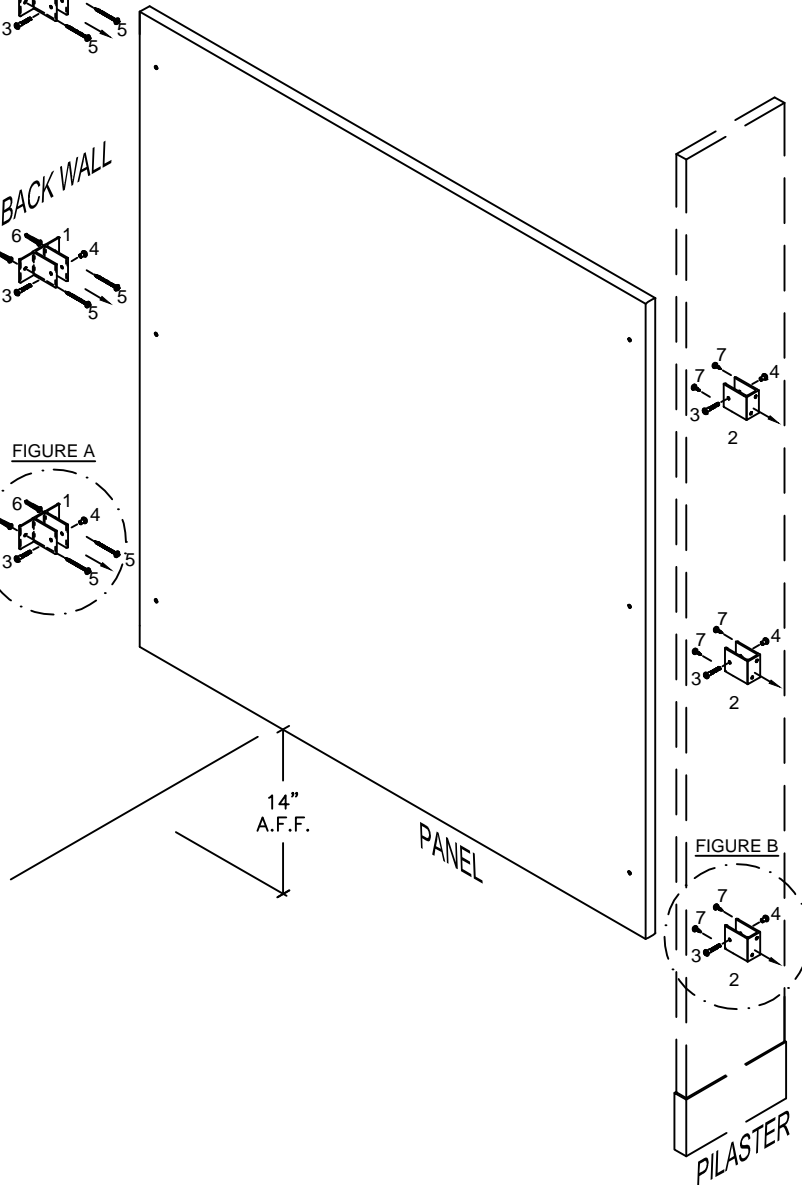

FIGURE B  
Panel to pilaster

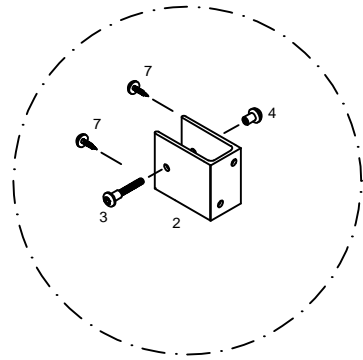

FIGURE B  
Panel to pilaster

**FLOOR ANCHORED/OVERHEAD BRACED  
PANEL TO PILASTER/WALL  
ONE EAR ASSEMBLY  
POLYMER**

Pilasters must be both plumb and level. To assist in leveling, headrail may be lightly positioned across adjacent pilasters(do not fasten at this time)

- A. Plumb panel and fasten panel to two ear bracket at wall with through bolts.
- B. Plumb pilaster and fasten pilaster to panel using through bolts..



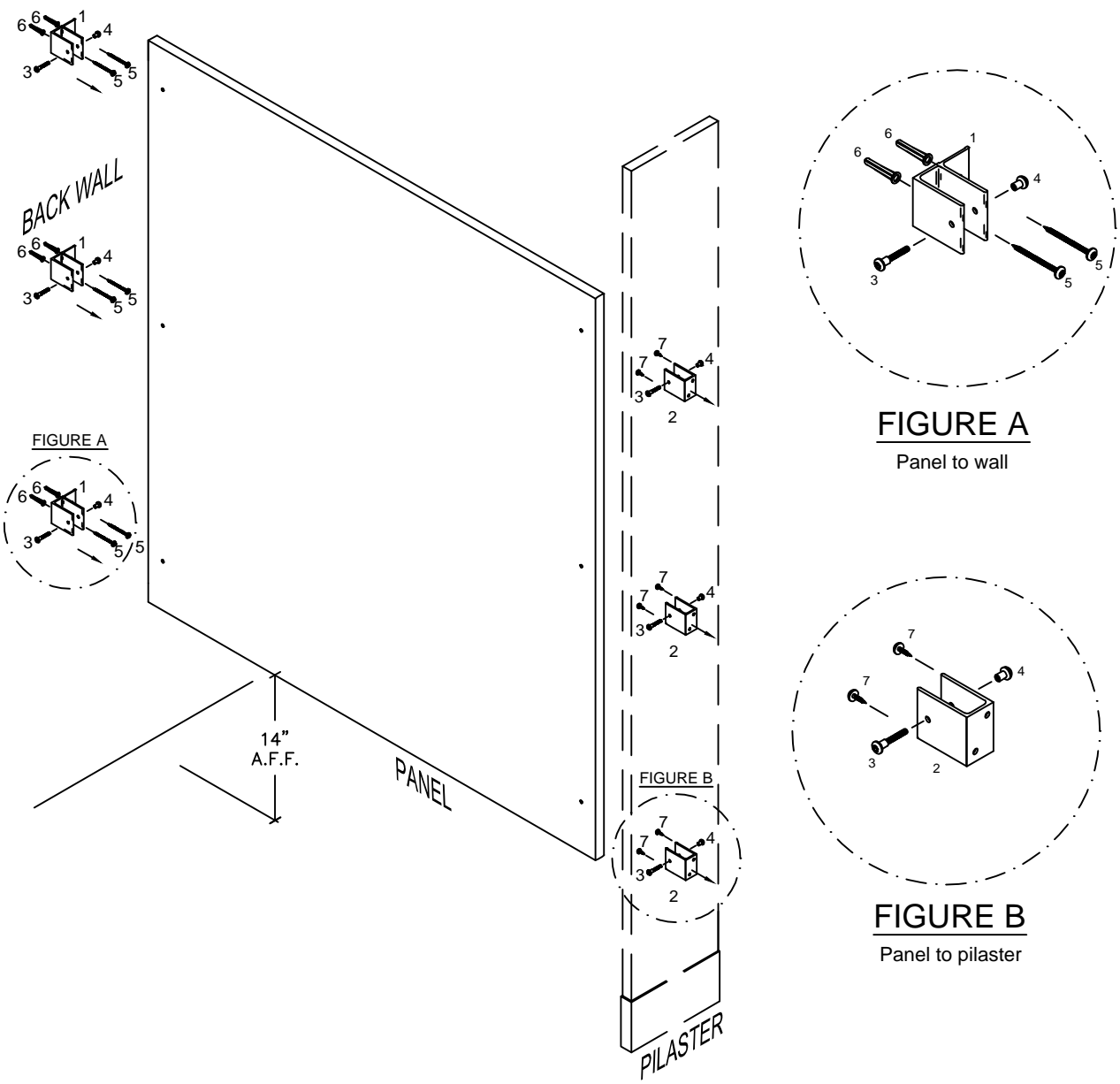



Panel Hardware Kit (P/N 8445010) Includes: ALUMINUM			
PART ID.		DESCRIPTION	QTY
1		One Ear Alum. Bracket	(3)
2		Alum. "U" Bracket	(3)
3		Vandal Resistant 1" Step Bolts	(6)
4		Vandal Resistant 5/8" Barrel Nut	(6)
5		Vandal Resistant 2 1/2" S.M.S	(6)
6		Plastic Shields	(6)
7		Vandal Resistant 5/8" S.M.S	(6)



**FLOOR ANCHORED/OVERHEAD BRACED  
PILASTER/WALL  
ASSEMBLY  
POLYMER**

Pilasters must be both plumb and level. To assist in leveling, headrail may be lightly positioned across adjacent pilasters(do not fasten at this time)

- A. Establish door openings by adjusting pilaster mounting bar & nuts to desired position and tightening.
- B. Plumb pilaster and fasten pilaster to wall brackets using through bolts.

Pilaster/Wall Hardware Kit (P/N 8445210) Includes: ALUMINUM			
PART ID.		DESCRIPTION	QTY
1		One Ear Wall Bracket	(3)
2		Vandal Resistant Step Bolts 1" Long	(3)
3		Vandal Resistant S/S Barrel Nut	(2)
4		Vandal Resistant 2 1/2" S.M.S	(6)
5		Plastic Shields	(6)
6		Vandal Resistant 3/4" S.M.S	(6)

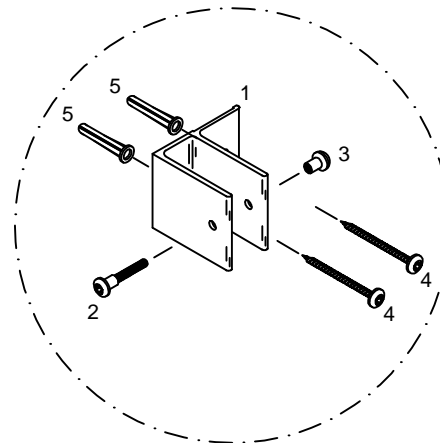
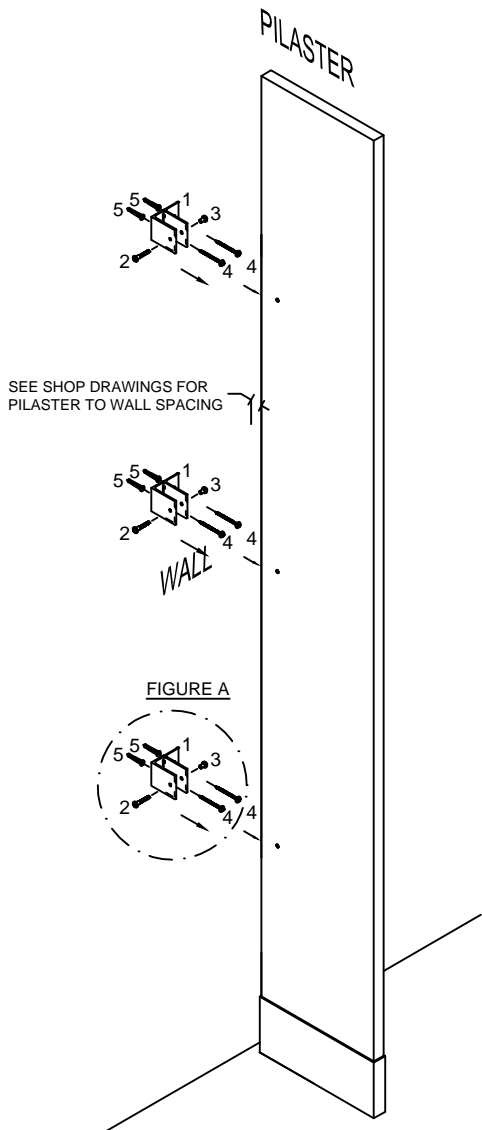
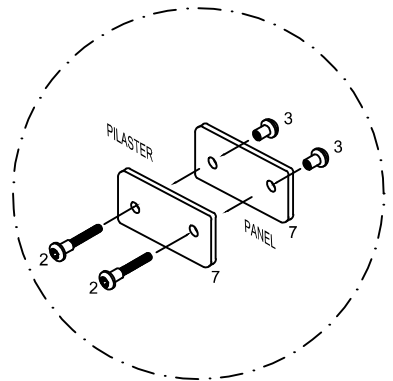
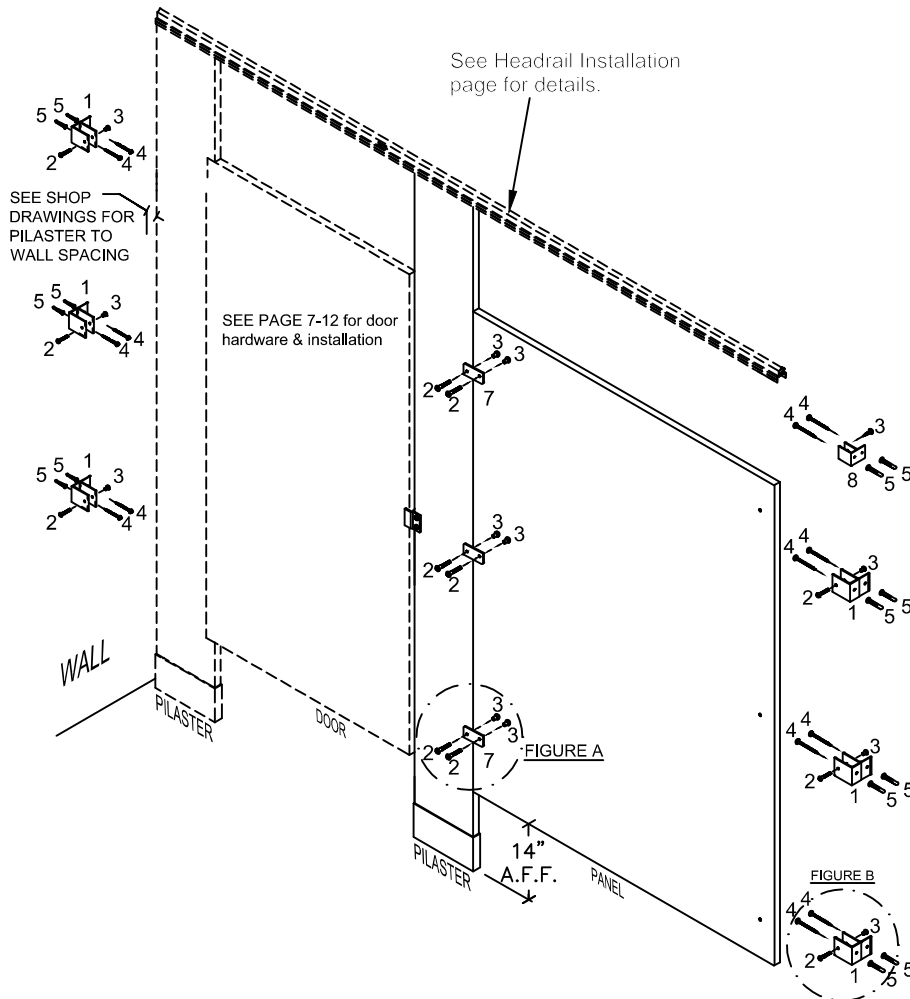

**FIGURE A**  
Pilaster to wall

**FLOOR ANCHORED/  
OVERHEAD BRACED  
PILASTER/PANEL ALCOVE  
ASSEMBLY  
POLYMER**

Optional #8447020 2-ear alcove kit.

Panel Hardware Kit (P/N 8447010) Includes: ALUMINUM			
PART ID.		DESCRIPTION	QTY
1		One Ear Alum. Bracket	(6)
2		Vandal Resistant 1" Step Bolts	(12)
3		Vandal Resistant 5/8" Barrel Nut	(12)
4		Vandal Resistant 2 1/2" SMS	(14)
5		Plastic Shields	(14)
6		Vandal Resistant 5/8" SMS	(3)
7		Alcove Clip S/S	(6)
8		Headrail Bracket	(1)



**FIGURE A**

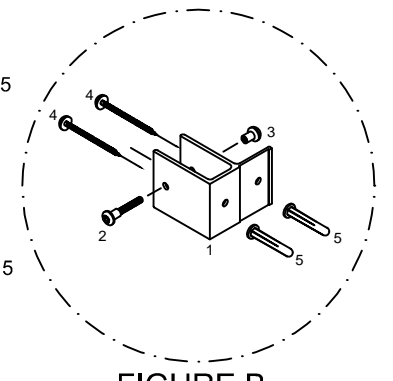

**FIGURE B**

**NOTE:**  
There will be no gap between the in-line panel and pilaster.

# Solid Plastic Stiffener Channel

SP8

The 75" Stiffener is used to provide added support to the pilasters.

**\*\*Locations will be shown on shop drawings\*\***

**Mount on inside of Hinge Side Pilaster**

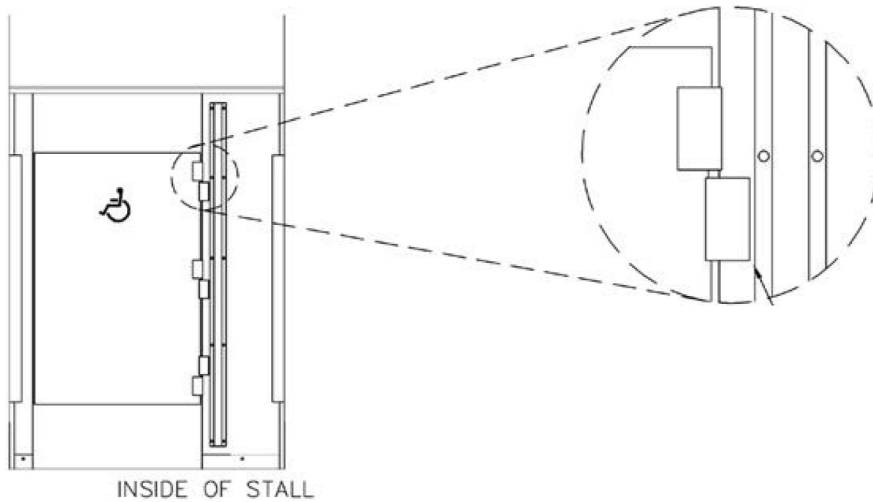

STD. FRONT ELEVATION  
N T S FOR REFERENCE ONLY

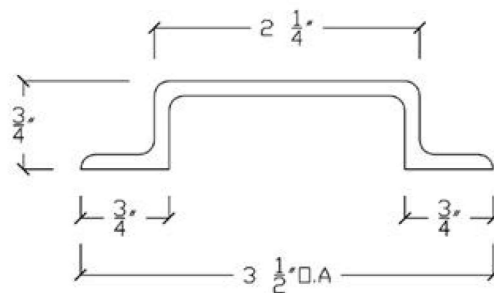

CROSS SECTION





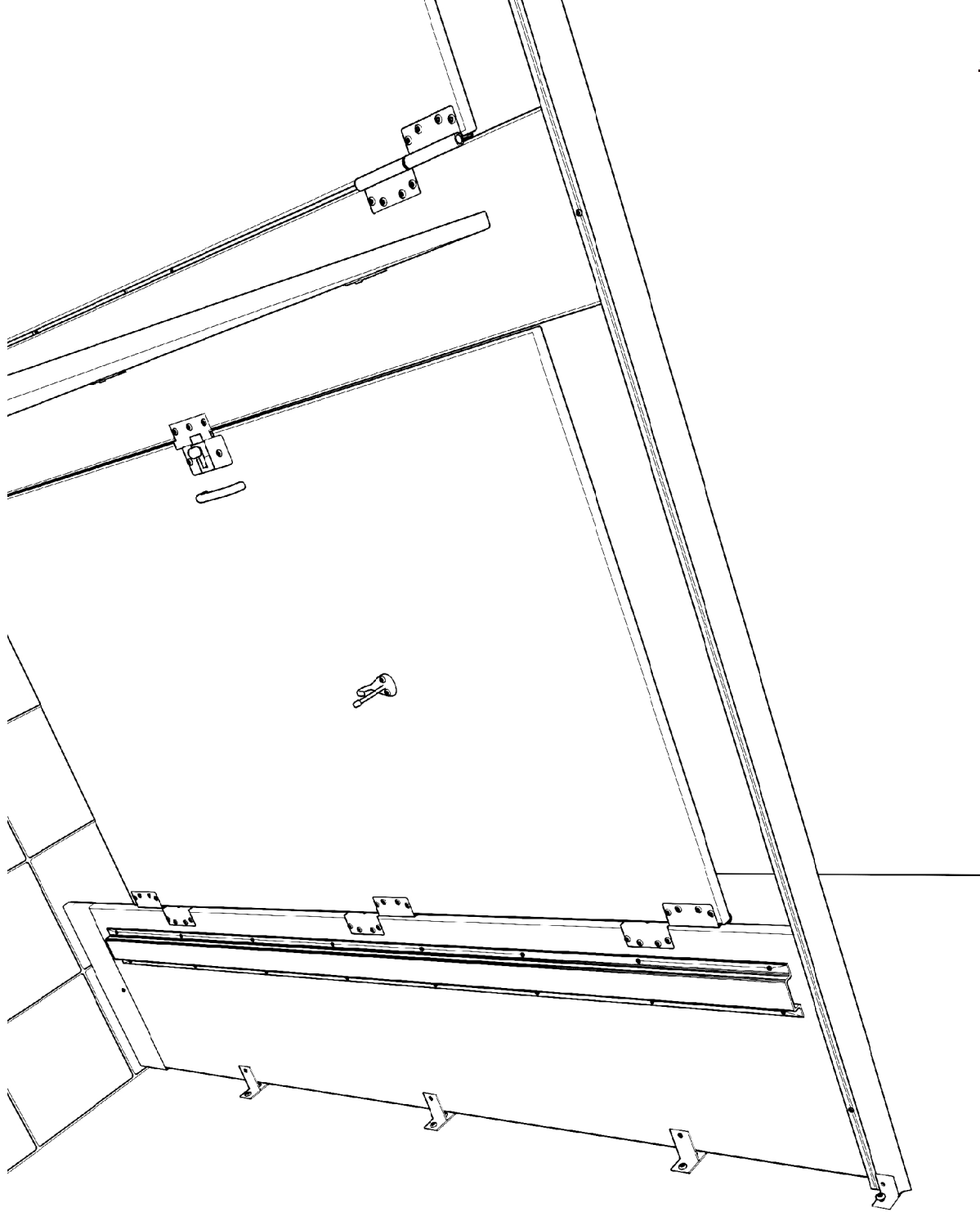

# Solid Plastic Stiffener Channel

SP10

The 75" Stiffener is used to provide added support to the pilasters.

**\*\*Locations will be shown on shop drawings\*\***

**Mount on inside of the Pilaster with Stop and Keeper for Support.**

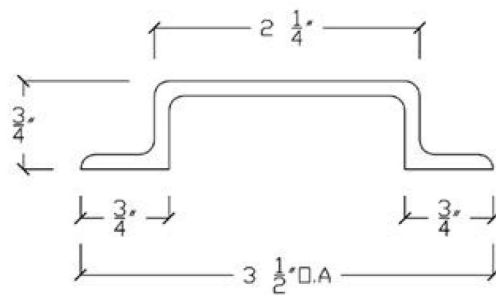

CROSS SECTION

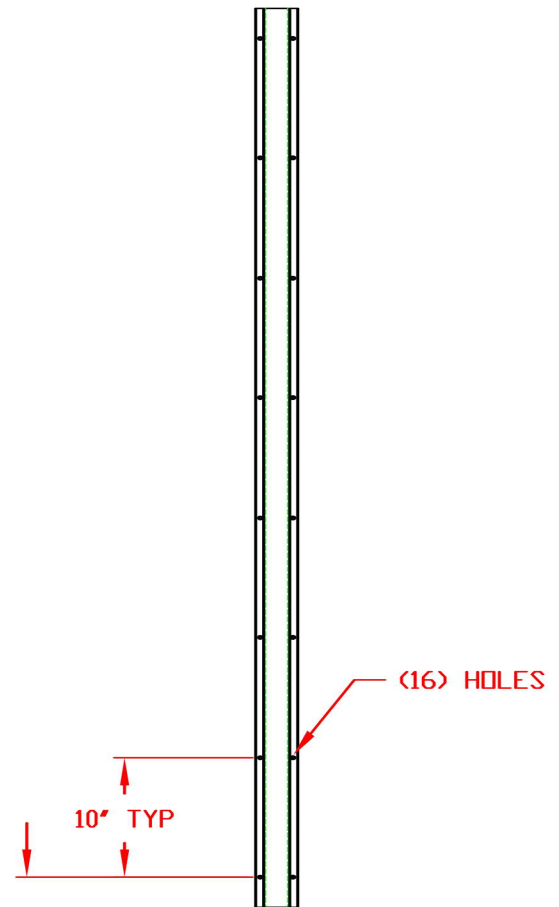

SP11

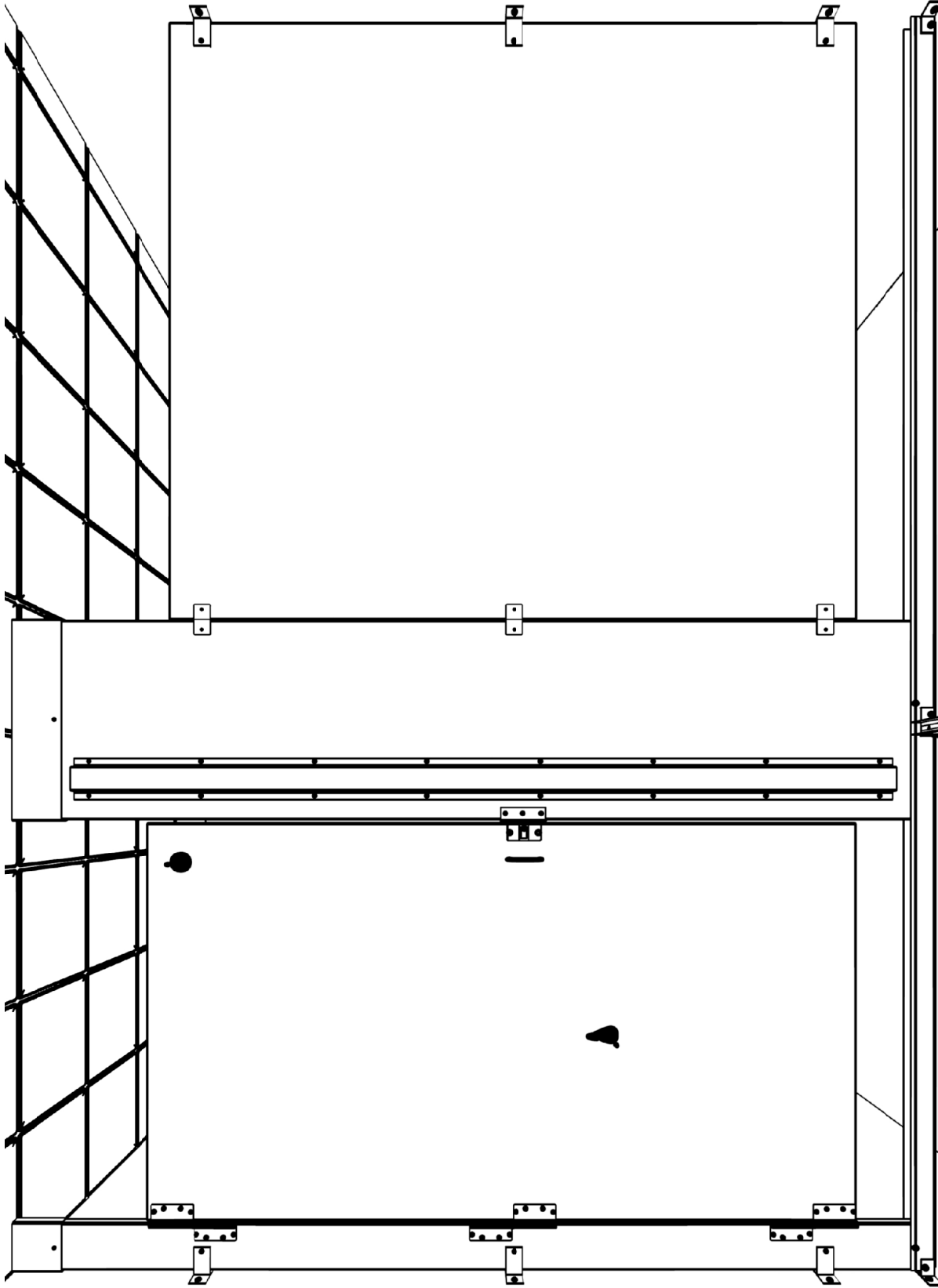

## DOOR HARDWARE INSWING 8" WRAP HINGE - POLYMER

### HINGES

Hinge kit will contain aluminum housings and toothed plastic inserts. Plastic cam (#3) will be inserted into one of the aluminum housings (#1). This will be the bottom half of the top hinge (pilaster side). Insert female plastic insert (#4) into an aluminum housing. This will be the top half of the upper hinge (door side). (To set closing position of door, mate toothed cam into aluminum housing until desired setting is achieved.)

Insert non-cammed hinge pin (#2) into an aluminum housing. This will be the top half of the lower hinge (pilaster side). The remaining female plastic insert should be placed into aluminum housing and coupled with other half of hinge. Proceed to mark door and secure hinges to edge of pilaster and door with flathead screws (#11) with the exception of the bottom door hinge. This will be secured after door is hung on pilaster.

Through-bolt all holes with provided step-bolts and barrel nuts.

### LATCH & BUMPER

Install slide latch at midpoint of the door, 27 1/2" inches up from the bottom of the door. Beveled side should face up to allow for emergency access when door is lifted.

Mount the slide latch on to the door with two (2) step bolts and two (2) barrel nuts. Install keeper and bumper on pilaster. Be sure that the keeper and bumper is set so that the slide bar of the slide latch engages the notch of the keeper. Install keeper/bumper with three (3) step bolts and three (3) barrel nuts.

Door Hardware Kit (P/N 8441007) Includes:		
PART ID.	DESCRIPTION	QTY
1	4" Aluminum Housings	(4)
2	Non-Cammed Hinge Pin Insert	(1)
3	Cammed Hinge Pin Insert	(1)
4	Female Plastic Insert	(2)
5	Stop and Keeper	(1)
6	Slide Latch	(1)
7	Tamper Resistant Step Bolts 1"	(21)
8	Tamper Resistant Barrel Nut 1/2"	(21)
9	Bumper And Coathook	(1)
10	Tamper Resistant Screw 5/8"	(2)
11	Flathead Screw 5/8"	(4)

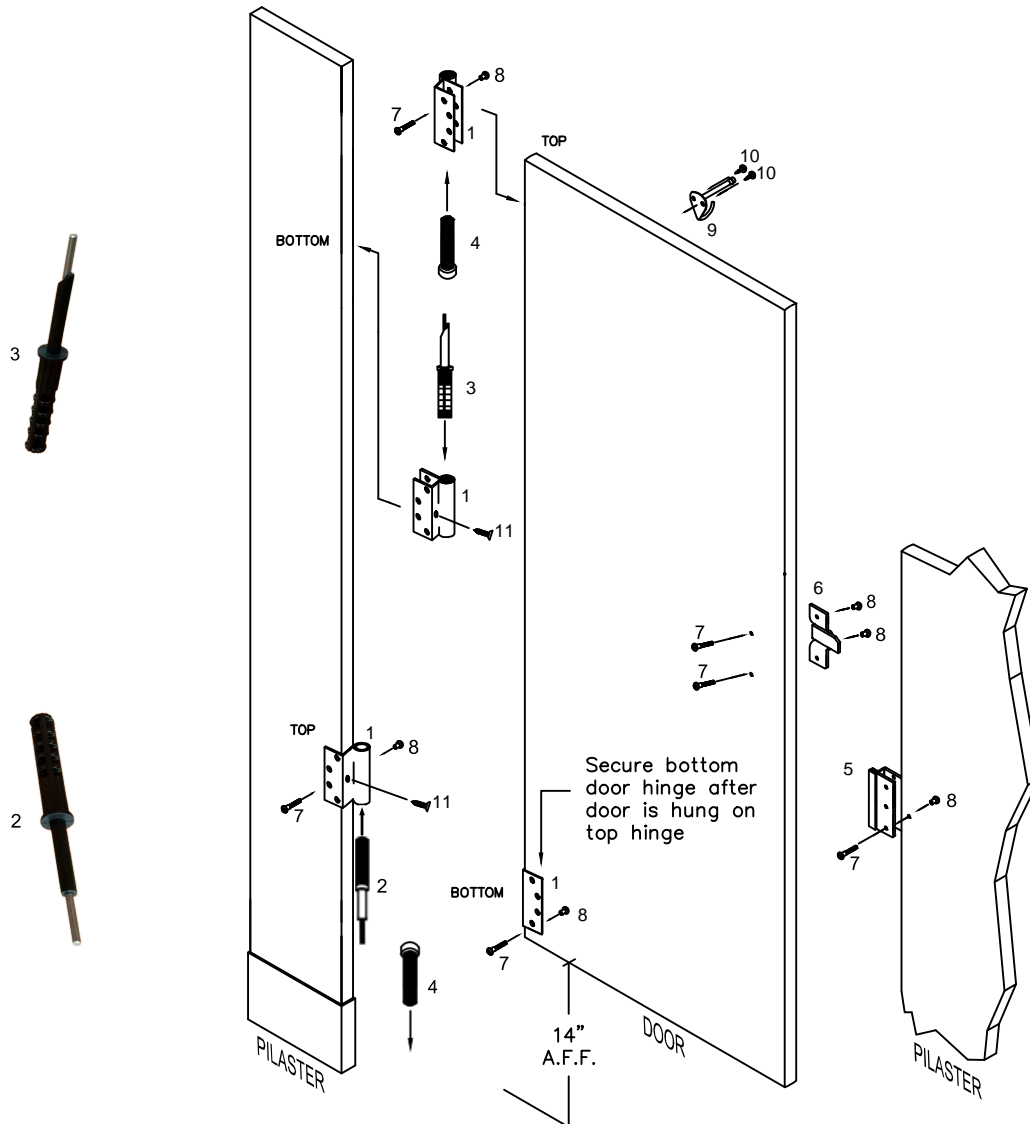

**DOOR HARDWARE OUTSWING  
8" WRAP HINGE - POLYMER**

HINGES

Hinge kit will contain aluminum housings and toothed plastic inserts. Plastic cam (#3) will be inserted into one of the aluminum housings (#1). This will be the bottom half of the top hinge (pilaster side). Insert female plastic insert (#4) into an aluminum housing. This will be the top half of the upper hinge (door side). (To set closing position of door, mate toothed cam into aluminum housing until desired setting is achieved.)











Insert non-cammed hinge pin (#2) into an aluminum housing. This will be the top half of the lower hinge (pilaster side). The remaining female plastic insert should be placed into aluminum housing and coupled with other half of hinge. Proceed to mark door and secure hinges to edge of pilaster and door with flathead screws (#11) with the exception of the bottom door hinge. This will be secured after door is hung on pilaster.

Through-bolt all holes with provided step-bolts and barrel nuts.

LATCH & BUMPER

Install slide latch at midpoint of the door, 27 1/2" inches up from the bottom of the door. Beveled side should face up to allow for emergency access when door is lifted.

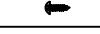
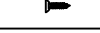
Mount the slide latch on to the door with two (2) step bolts and two (2) barrel nuts. Install keeper and bumper on pilaster. Be sure that the keeper and bumper is set so that the slide bar of the slide latch engages the notch of the keeper. Install keeper/bumper with three (3) step bolts and three (3) barrel nuts.

Door Hardware Kit (P/N 8441008) Includes:		
PART ID.	DESCRIPTION	QTY
1	 4" Aluminum Housings	(4)
2	 Non-Cammed Hinge Pin Insert	(1)
3	 Cammed Hinge Pin Insert	(1)
4	 Female Plastic Inserts	(2)
5	 Stop and Keeper	(1)
6	 Slide Latch	(1)
7	 Vandal Resistant S/S Step Bolts 1"	(27)
8	 Vandal Resistant S/S Barrel Nut	(27)
9	 Bumper And Coathook	(1)
10	 Vandal Resistant S/S Screw	(2)
11	 Flathead S/S Screw 5/8"	(4)
13	 Vandal Resistant S/S Step Bolts 1.25"	(2)
21	 Door Pull Handles	(4)

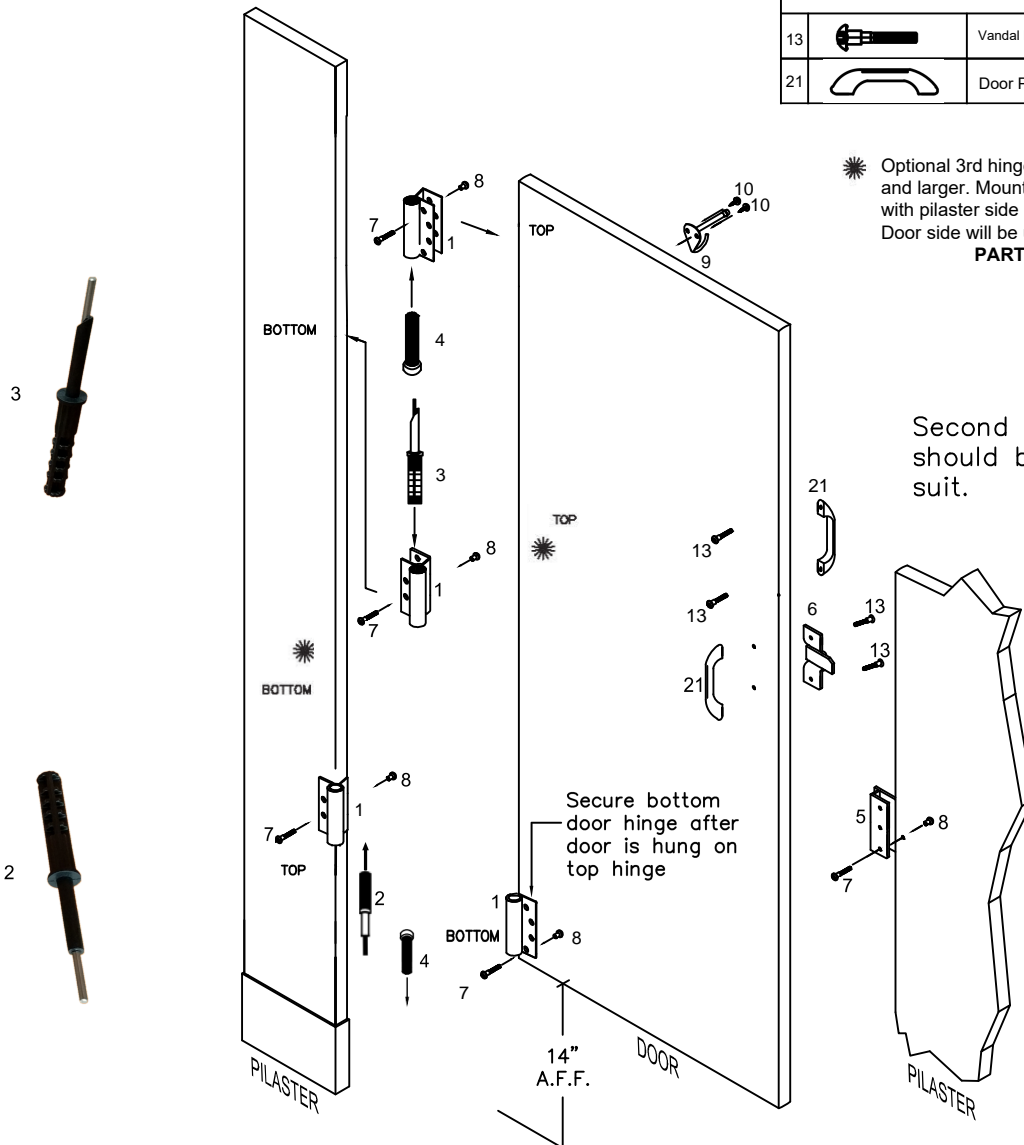





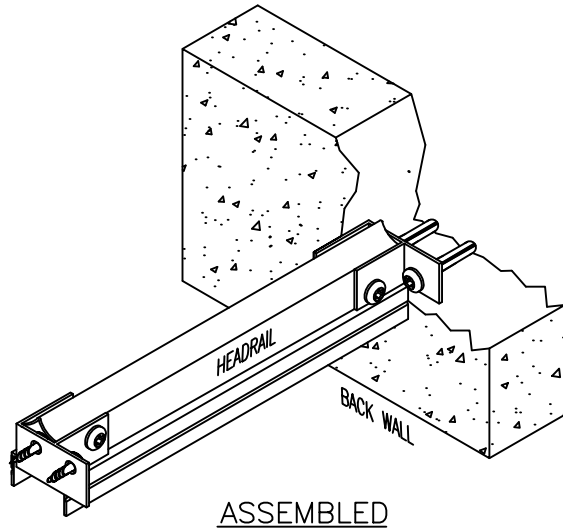

\* Optional 3rd hinge may be used on Doors 32" and larger. Mount between two standard hinges with pilaster side hinge as lower half fit with pin. Door side will be upper and fit female insert.  
**PART # 40-8442890**

Second door pull should be placed to suit.

**HEADRAIL  
ASSEMBLY  
POLYMER**



Headrail Hardware Kit (P/N 8448100) Includes:		
PART ID.	DESCRIPTION	QTY
1	 Headrail Satin "F" Zamac Bracket	(2)
2	 Headrail Cap Satin Zamac	(1)
3	 Vandal Resistant 2 1/2" S.M.S	(2)
4	 Plastic Shield 14/16 x 1-1/2"	(2)
5	 Vandal Resistant 5/8" S.M.S	(4)
5	 Theft Resistant S/S #14 x 5/8" S.M.S	(x)

Additional Vandal Resistant 5/8" S.M.S will be included based upon headrail length



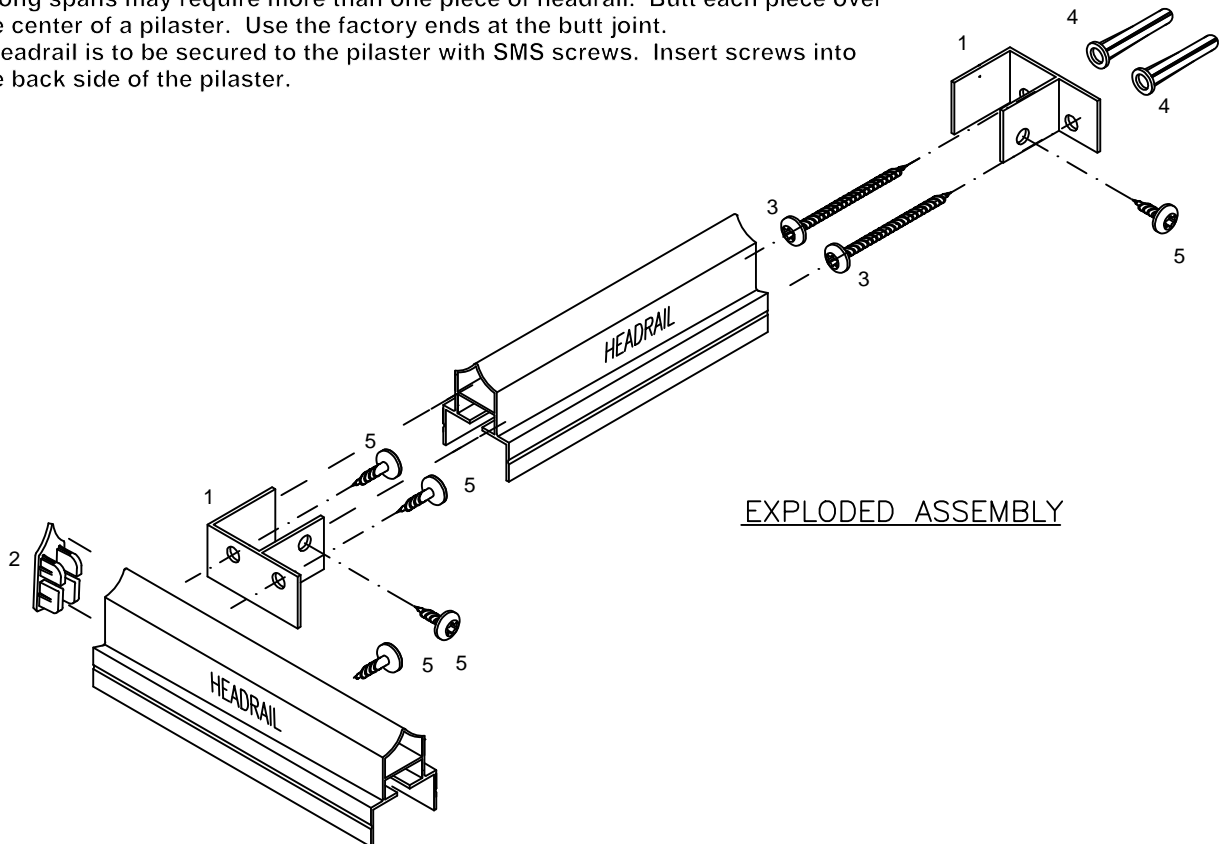

**\*\*Notes:**

- Headrail comes in standard 65" and 98" lengths.
- Headrail is to be cut to size in the field. See drawings for details and locations.
- Long spans may require more than one piece of headrail. Butt each piece over the center of a pilaster. Use the factory ends at the butt joint.
- Headrail is to be secured to the pilaster with SMS screws. Insert screws into the back side of the pilaster.



**URINAL SCREEN FULL HEIGHT  
ASSEMBLY  
POLYMER**

- A. Before proceeding, confirm that backing of wall is adequate to support and secure mounting of urinal screens.
- B. Insert anchoring devices in walls and secure wall brackets.
- C. Place urinal screen on a support, 14" above the floor.
- D. Set it into wall bracket and fasten urinal screen with through bolts at this time.

Urinal Screen Hardware Kit (P/N 8449000) Includes: ALUMINUM FULL HEIGHT			
PART ID.		DESCRIPTION	QTY
1		38" Long Two Ear Wall U/S Bracket	(1)
2		Vandal Resistant 2 1/2" S.M.S	(8)
3		Plastic Shields	(8)
4		Vandal Resistant S/S Step Bolts 1" Long	(4)
5		Vandal Resistant S/S Barrel Nut	(4)

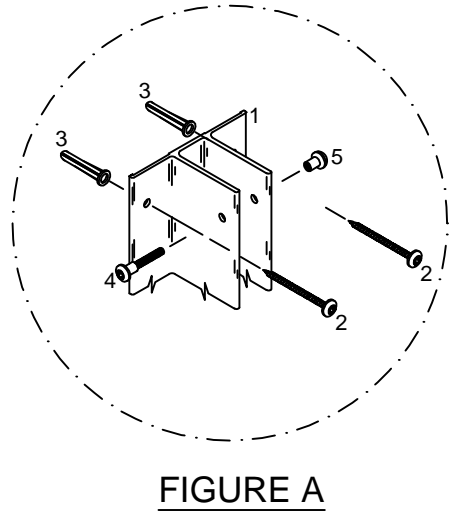
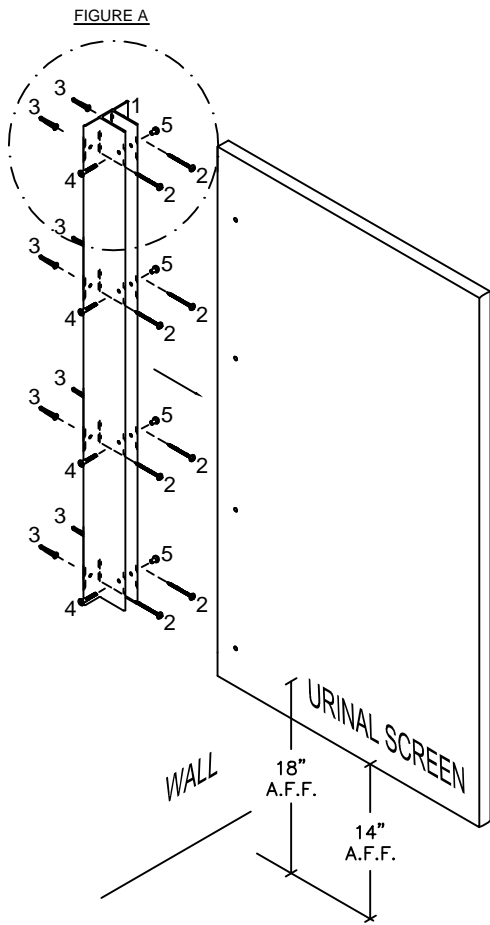



## **CARE AND MAINTENANCE OF TOILET PARTITIONS**

In order to provide toilet partitions with the care and maintenance, the following instructions must be followed.

A. All surfaces must be kept clean with water and a mild soap solution only.

B. In order to provide toilet partitions with the proper care and maintenance, the above instructions must be followed.

## **WARNING**

Under no circumstances should these components be subjected to:

- \*Abrasive powders or pads
- \*Water closet cleaners
- \*Ceramic tile cleaners
- \*Solutions containing more than 1% by volume of ammonia
- \*Solutions containing acids or lye
- \*Solutions containing enzymes

Attention to work progress during new construction or renovation is important.

Other trades and cleaning services may use agents for ceramics and tiles that will damage these components



## SOLID PLASTIC WARRANTY

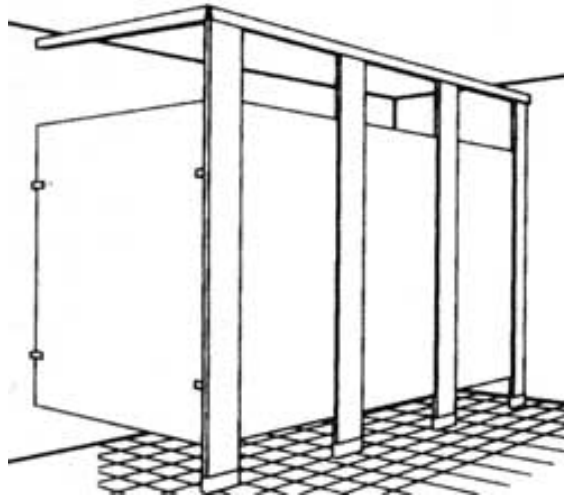

**One Point Partitions** guarantees its solid plastic high-density polyethylene (HDPE) partitions, properly maintained, against breakage, corrosion, and delamination for **25 YEARS** from the date of receipt by the customer. If material is found defective during that period, the material shall be replaced free of charge. No credits or allowances shall be issued for any labor or expenses relating to the replacement of components covered under the warranty plan.

This warranty shall not be applicable if vandalism or improper cleaning/maintenance of partitions has contributed as just cause for partition failure.